

**CHAPTER 5**

**WASTEWATER**



---

**CHAPTER 5**

**WASTEWATER**

**PART 1 DESIGN**

**5.1.1 INTRODUCTION**

This part sets out the basic design principles for the drainage of wastewater. While some construction information is included for completeness, detailed information on construction will be found in Part 2 “Construction” in Chapter 4 of this manual. Generally, the construction and testing of waste water reticulation mains and structures will be in accordance with the requirements for stormwater detailed in Chapter 4.

**5.1.2 GENERAL**

All lots within 200m of the boundary of an existing wastewater drainage system shall be provided with a connection to that system.

Where the existing lot being subdivided is within 200m of the boundary of an existing wastewater drainage system and is presently being serviced with a septic tank, then the existing lot and all new lots shall be connected to the drainage system as a condition of the development.

All wastewater drainage systems shall be capable of serving the entire natural catchment upstream of the actual system. The flow from the upper section of the catchment shall generally be calculated assuming complete urbanisation of the area or the inclusion of such other specific uses as the Engineer may require.

Provision may be required for the design to allow for the flow from a pumping station outside the natural catchment, the details being supplied by the Engineer. A contribution towards the additional cost of the gravity system will be considered by Council where allowance for a pumping station flow is required.

Where a proposed Development which will discharge to the existing reticulation system is determined by the Engineer to be “high density” eg multi-storey residential apartments, the Developer may be required to meet all or part of the costs of a catchment analysis to establish the capacity of the existing sewage system to cope with the increased flow.

No person, other than the authorised agents of Council, shall make connections to the waste water drainage system without the approval of the Engineer.

No surface water run-off shall be connected to any waste water drainage system.

No waste water drainage line shall be connected to a storm water pipe.

Where required by the nature of the business or commercial activity to be carried out on any lot, provision may need to be made for the pre-treatment of the discharged waste, or for the installation of an on-site grease trap in accordance with the provisions of the Trade Waste Bylaw.

### 5.1.2.1 Provision for Future Development

The Council may require the Developer to install a reticulation system with a greater capacity than that required for the development in order to service future developments, or to upgrade the present level of service.

Consideration in the design of the reticulation system should be given to the potential for the change of use of the lots being created, especially in commercial and industrial subdivisions. In such cases, the Council may by agreement negotiate with the Developer and make a financial contribution to the additional costs that may be incurred. Such an agreement shall be made in writing with the Council, preferably before the issue of a Resource Consent, and before the commencement of construction.

### 5.1.3 STANDARDS

The list of Standards specified in Chapter 4, Clause 4.1.3 shall also be applicable to this section of this Manual.

### 5.1.4 CALCULATION OF FLOWS

Flow requirements shall be calculated from the District Plan zoning for the subdivision for the greatest flow possible from the catchment in question, and shall be to the Engineer's approval. Specific calculations are to be carried out using the following data.

#### 5.1.4.1 Domestic Flow

Average sewage flow = 200 litres per head per day  
Peak & dilution flow factor = 5 times daily average sewage flow  
Minimum velocity = 0.75 metres per second

**Note:** Velocities shall be calculated with due allowance for the proportional depth of flow in the sewer.

#### 5.1.4.2 Industrial Flow

Specific design will be required within each industrial subdivision and to assess the future upstream flow.

The following maybe used as a preliminary design basis:

Industry Type (water usage)	Minimum design flow (litres/second/hectare)
Light	0.4
Medium	0.7
Heavy	1.3

The above design flows include both normal sanitary sewage and trade wastes.

### 5.1.5 LOCATION OF PIPELINES

All wastewater sewers shall be located inside the road reserve boundary unless it is not technically possible to do otherwise, but shall be located in such a manner as not to reduce the building area available on the lots.

Every effort shall be made to eliminate surface water infiltration of the waste water system. Manholes shall not be located adjacent to road kerbs and channels or at low points in the finished ground surface, or in secondary storm water flow paths.

Waste water lines in roads shall generally be aligned parallel to the kerb lines within the carriageway and shall be installed with adequate clearance from other services so as to allow for the maintenance of those services, and for the provision of additional future services.

#### 5.1.5.1 Public Sewers in Private Property

When planning sewers in private properties, consideration should be given to maintenance requirements and likely future developments within the property boundaries.

Where, as a result of a subdivision or development, an existing or a proposed public sewer will be within a private property, the pipeline shall be protected by an easement in favour of Council. The easement shall be a minimum width of 3.0m and at least 1.5m on either side of the pipeline.

#### 5.1.5.2 Structures Over or Adjacent to Public Sewers

Building over or adjacent to public waste water lines is not a permitted activity.

Rising mains and waste water falling mains shall not be sited under buildings, and the centre line of the pipe shall not be closer to a building than the greater of:

- a) 1.5m or
- b) Half the depth to the invert of the waste water line, plus 0.6m, subject to compliance with Clause 3.1 of NZS 3604.

Where (a) and (b) above cannot be complied with, and the building cannot be sited elsewhere on the property or modified to conform with the above conditions, and it is essential for the proposed building to be sited on that part of the property, approval may be granted for non-residential ancillary buildings over the waste water line subject to the following conditions and with the approval of the Engineer.

- Compliance with Clause 7.6.2 of the Whakatane District Council Consolidated Bylaw 1997
- There are no changes in direction or junctions in the portion of line to be built over.

### 5.1.6 PIPE SIZES

In no case shall a public sanitary sewer line be less than 150mm internal diameter.

### 5.1.7 GRADIENTS

Pipe gradients shall be determined using the Colebrook White formula. Specific approval of the Engineer is required and shall be obtained prior to the submission of detailed design if the minimum gradients shown in Table 5.1 cannot be achieved. The pipeline design shall take the following factors into account:

- The pipe roughness coefficient  $k_s$ , used in the design shall be that nominated by or agreed upon with the Engineer on the basis of commonly adopted modern engineering design practice. For preliminary design purposes, it is recommended that  $k_s$  be assumed 1.5mm as an overall coefficient allowing for joints and so on
- The desirable flow velocity in 150mm diameter pipes when full shall normally be not less than 0.65 metre/second (minimum gradient 0.55%), but 0.75 metre/second (minimum gradient 0.72%) shall be the desirable minimum velocity for the upper portions of sanitary sewer systems
- Gradients flatter than 0.55% for 150mm diameter pipes may be permitted in special cases where pumping would otherwise be required
- A 150mm diameter pipeline at a gradient of 0.75% has 14 litre/second capacity (equivalent to 300 houses or 1,200 people)
- A 150mm diameter pipeline at a gradient of 0.55% has 12 litre/second capacity (equivalent to 257 houses or 1,030 people)
- In practical terms, unless the catchment exceeds 250 houses, dwelling units, or their equivalent, and where no flow from a pumping station is involved, 150mm diameter pipes laid within the above limits will be adequate without specific hydraulic design
- In flat or rolling country every effort should be made in the design to have the sewers as steep as reasonably possible.

Table 5.1 - Minimum Pipe Gradients

Table 5 1: Minimum Pipe Gradient for Different Pipe Diameters	
Pipe Diameter (mm)	Minimum Gradient (%)
150	0.55
200	0.37
225	0.34
300	0.30

These gradients shall be subject to clause 5.1.7 above and are for full pipes.

Where the velocity and gradient limits cannot possibly be complied with, the Engineer may require certain additional works to ensure satisfactory operation of the system.

### 5.1.8 PIPES

Pipe products that may be used for wastewater pipeline work are shown in Clause 4.2.3 in Section 2 of Chapter 4.

---

Concrete lined steel pipes may be used where additional strength is required eg on steep gradients or at shallow depths under carriageways.

Where concrete-lined steel pipes are included in the design, these shall be as specified in Clause 4.2.3.

Generally, sewers shall be PVC plain solid wall, rubber ring jointed pipes and fittings complying with AS/NZS 1260 ; 2002 Class SN 16.

Where the depth of the sewer is greater than 6m, or wheel traffic loads exceed 96 kN, specific design of the pipeline using AS/NZS 2566 design method will be required.

PE pipes complying with AS/NZS 4130 may be used in specific circumstances (e.g. for sleeving) with the approval of the Engineer.

### **5.1.9 JOINTS**

All joints shall comply with the following requirements:

- All pipes shall have flexible joints of an approved type such as rubber rings
- Steel pipes shall have flexible joints
- Solvent cement joints shall only be used for PVC pipes where specifically approved by the Engineer
- Joints shall be provided adjacent to manholes to the requirements of NZS/AS 2566 : 1988 with the exception of PVC, where proprietary connections may be used.

### **5.1.10 PIPE BEDDING**

Pipe bedding shall be designed to meet the requirements of the class of pipe used, under the design loading conditions set out in the manufacturer's specifications.

Generally, pipe bedding aggregate shall consist of graded chip or pea metal, all passing a 9.5mm sieve and retained on a 4.75mm sieve, placed and compacted in accordance with Clause 4.2.11.2 of Section 4.

### **5.1.11 PIPELINE CONSTRUCTION**

The construction of all pipelines shall be carried out in accordance with the requirements of Section 2 of Chapter 4 of this Manual.

### **5.1.12 MINIMUM COVER AND MAXIMUM DEPTH**

All pipelines other than those in private property shall be specifically designed to support the likely loading in relation to the minimum cover to be provided in accordance with requirements of NZS/AS 3725 : 1989 Generally, the minimum cover for all types of pipes [other than those in private property] under all conditions shall be 600mm.

The minimum cover over pipes in private property shall be 500mm. Where, due to the topography, this cover cannot be provided, the pipeline shall be protected. Specific design information will be required in these circumstances.

---

Where pipes are designed below carriageways, they shall be specifically designed to support the pavement design loading appropriate to the minimum cover to be provided at both subgrade and finished level.

Generally, waste water lines deeper than 2.5m should be avoided, and approval for such installations will be given only under special circumstances.

### **5.1.13 MANHOLES**

#### **5.1.13.1 Manhole Locations**

Manholes shall be provided at every change of direction, at every main junction, at every change of gradient or change of pipe size, at distances apart not exceeding 100 metres and at the end of every line, except where otherwise approved by the Engineer. A manhole will be required at the termination of all pipelines greater than 35 metres in length.

#### **5.1.13.2 Standard Manholes**

Where the depth to invert exceeds one metre a manhole is to be constructed in accordance with Standard Drawing SS 05.

Precast manholes shall be a minimum of 1050mm in diameter.

Manhole steps shall be provided in accordance with Clause 4.2.13.9.

#### **5.1.13.3 Shallow Manholes**

Where the depth to invert of the manhole is less than one metre and it is serving less than four houses, a shallow type manhole may be constructed with a minimum diameter of 600mm. In all cases, shallow manholes shall be of sufficient dimension to allow full benching.

Refer to Standard Drawing SW 04.

#### **5.1.13.4 Fall through Manholes**

Where there is a change of direction in a manhole, the loss of velocity at the change of direction must be compensated for by a drop of 10mm plus 3mm for every 15° of change of direction. This applies for velocities up to 1.2 metres per second.

For higher velocities:

$$\text{Drop} = 10\text{mm} + \frac{(\text{Angle of Deviation} \times V^2\text{mm})}{7.5}$$

The minimum fall allowable is 15mm.

Where an increase in pipe size occurs, the soffit(s) of the inlet(s) shall not be lower than the soffit of the outlet. This will also apply to multiple inlets subject always to the requirement for minimum fall through the manhole in respect of each pipe.



#### **5.1.13.5 Unsuitable Ground**

Where a manhole is to be constructed on unsuitable foundation conditions, the area under the manhole shall be undercut down to solid ground or until suitable conditions are reached and backfilled up to the underside of the manhole base with compacted hardfill.

### **5.1.14 CONNECTIONS**

#### **5.1.14.1 General**

All individual dwellings, lots or titles shall be provided with a connection to the wastewater main in accordance with the following requirements:

- The connection provided for each lot shall be of a type capable of taking an approved drain pipe of 100mm internal diameter, unless a larger size is required by design
- Where the sanitary sewer main is outside the lot to be served, the connection shall extend to at least 500mm within the boundary of the lot
- Where the connection will cross more than one lot boundary, then specific approval of the Engineer will be required
- If the above conditions cannot be met, then a 150mm diameter branch sewer line shall be constructed complete with a terminal manhole, or with a cleaning eye in accordance with clause 5.1.15

Where it is proposed to utilise an existing connection as a part of a development the following conditions shall be complied with:

- The existing connection shall be inspected with a video camera to establish its condition
- Where the connection passes the inspection, the new lateral may be connected to the existing connection by installing a manhole at the property boundary as shown on Standard Drawing SS 10
- If the lateral does not pass the inspection it shall be upgraded to meet the current standards required for all new installations
- All costs associated with inspection and upgrading shall be borne by the Developer

#### **5.1.14.2 Sealing**

All connections, whether into reticulation lines or into manholes shall be sealed at the end by a factory manufactured removable blank cap fitted with a rubber ring. Connections shall conform to the details in Standard Drawing SS 01.

#### **5.1.14.3 Connections to Pipelines**

Connections and junctions to the main shall be accomplished as detailed in Standard Drawing SS 01. The level of the connection shall be constructed to terminate at the level appropriate to service the building site but shall be not less than 1.2 m deep.

#### **5.1.14.4 Saddling**

Saddling of pipes for connections will not be permitted unless specifically approved by the Engineer.

#### **5.1.14.5 Marker Posts**

The termination of a house connection shall be marked by a 50mm x 50mm H4 treated timber marker post painted red in accordance with Clause 4.2.14.10.

#### **5.1.14.6 Branch Connections**

Where lengths of 100mm diameter branch connections are provided to service individual lots, these shall be constructed of uPVC pipes.

All specification clauses above relating to pipes, trenching, excavation, pipe laying, backfilling, etc, as detailed for main reticulation lines, shall apply to the construction of these connections.

#### **5.1.14.7 Drop Connections**

Where the fall in a manhole exceeds 500mm, a drop connection is required in accordance with Standard Drawings SS 02 and SS 03. Where the fall is less than 500mm but greater than 200mm, falls shall be constructed as ramps from the incoming pipe to the channel invert.

External drops shall be used on 150mm or greater diameter lines unless otherwise agreed to by the Engineer.

#### **5.1.14.8 Connections to Drop Manholes**

Where an existing or proposed sewer is more than 5m deep to the invert, or where required by ground conditions, the connection shall be designed as a manhole constructed on the deep line and a shallower branch line shall be laid from the manhole.

#### **5.1.15 CLEANING EYES**

Cleaning eyes may be constructed, after obtaining prior approval in writing from the Engineer. They shall be constructed in accordance with the Standard Drawing SS 04. All connections must be provided downstream of the cleaning eye. A cleaning eye may only be placed on a terminating 150mm diameter line less than 35m long.

#### **5.1.16 TESTING**

##### **5.1.16.1 Pipe Testing**

All wastewater mains and branch lines, including extended connections shall be pretested during construction, before testing in the presence of the Engineer, which shall be carried out at the completion of all other engineering works in the subdivision. The subdivider shall supply all equipment required to carry out the tests. Test requirements are set out in Clause 4.2.15.

### **5.1.16.2 Manhole Testing**

Manholes will be tested for water tightness by filling for 30 minutes. The allowable loss shall not exceed 1 litre per metre of depth. Care must be taken that undue pressure is not put on any of the downstream sewer pipes while this test is taking place.

## **5.1.17 PIPELINE TRACING**

The location of all pumping mains and gravity pressure mains (swallows) shall be marked with a foil tape or wire trace buried in the trench.

### **5.1.17.1 Tracer Tape**

Tracer tape shall be 50mm wide, woven reinforced, manufactured from acid and alkali resistant polythene plastic, with a solid aluminium core which shall be visible from both sides. The foil shall be continuously printed with "CAUTION SEWER MAIN BURIED BELOW", with no inks or printing extending to the edges of the tape.

All printing shall be encased to avoid ink rub-off. The adhesives that bond the protective plastic jacket to both sides of the foil shall be applied to both sides to the film and foil layers to provide a continuous seal.

The tape shall be buried above the centre line of the pipe 300mm to 400mm below the finished surface. The tape shall be brought up inside the surface box risers or manholes at the start and end of the main with a 300mm long tail, so that pipe location equipment can be readily connected.

### **5.1.17.2 Tracer Wire**

When a pumping main or swallow pipe is installed by a directional drilling method or is bored through the ground for a distance exceeding 20 metres, the pipe shall have a tracer wire attached. The wire shall be a continuous 2.5mm<sup>2</sup> multi strand polythene sleeved cable, strapped to the pipe wall with at least two complete wraps of heavy duty adhesive tape, at no more than 3.0m intervals. The tracer wire shall be terminated at each end as for tape in section 5.1.17.1 above.

## **5.1.18 PUMP STATIONS**

### **5.1.18.1 General**

Where a proposed development cannot be adequately serviced by a gravity system, public sanitary sewage pumping stations will be permitted provided they are logically located and designed to service the entire catchment area of the land beyond the reach of the existing gravity system.

The design life of the pumping station shall be not less than 50 years.

Where isolated building sites cannot be provided with a gravity connection, consideration may be given to the use of individual privately owned sewage pump stations.

---

A sewage pumping station shall be capable of servicing the entire catchment for land uses likely to prevail during its economic life, and shall, where necessary for sound engineering design practice, accommodate pumped flows from adjacent areas.

The consent holder undertaking the development shall obtain a Discharge Consent from Environment BOP for any emergency overflow from the pump station if required.

Public sewage pumping stations shall be designed generally in accordance with the Standard Drawings and shall be vested in the Whakatane District Council. They shall meet the requirements of the Resource Management Act 1991, shall be subject to the Engineer's specific approval, and shall meet the following minimum requirements:

- Residential pump stations shall be designed for a peak flow calculated in accordance with Clause 5.1.4.1 above with a minimum of 1000 litres per person per day for the full development catchment. The capacity of other pump stations will be subject to specific design and must be approved by the Engineer
- A minimum of eight hours on-site emergency storage shall be provided, based on the average dry weather flow, measured between the overflow and the first stage alarm
- Storage in upstream pipes and manholes may be used in calculating the storage volume.

#### **5.1.18.2 Site and Layout**

The layout of the site of a sewer pump station will require the specific approval of the Engineer and will meet the requirements set out below.

The site layout and pump station shall be as follows:

- Pump stations shall be located on a separate lot solely for that purpose and shall be provided with a permanent all-weather access of not less than 2.7m paved width.
- The vehicle access shall be designed to accommodate a standard 8metre rigid truck, with suitable corner widening
- An adequate turning area shall be incorporated adjoining the station wet well and control cabinet to accommodate light commercial maintenance vehicles
- The pump station lid levels shall be provided with suitable freeboard above a 1% AEP flood level. This will be of particular concern where the pump station access is also being utilised as a designated secondary flow path
- The site shall be contoured in such a way as to prevent entry of surface runoff into the station.
- Where a storage well, in addition to the pump wet well, is to be provided, it shall be positioned to allow ready access in close proximity to the valve chamber
- The pump station lot shall be fenced to the Engineer's satisfaction
- A 150mm wide mowing strip at ground level shall be provided around the wet well, the valve chamber, the electrical cubicle and the boundary fence.

---

### 5.1.18.3 Pump Design

All pumps shall comply with the following requirements;

- Pumps shall be "Flygt" 3 phase submersible type and be fitted with impellers having a minimum throughlet of 75mm. In isolated small stations where this is not achievable, either a cutter or grinder type shall be used
- There shall be a minimum of two identical pumps in all pump stations, and each shall be capable of discharging the design peak flow
- Each pump shall be capable of pumping a peak flow calculated as per section 5.1.4
- Pumps shall be fitted with thermistors embedded in their windings. The thermistors shall be wired to the pump control system for the protection of the motors
- In selecting the appropriate pumps the operating conditions shall correspond as closely as possible to the point of maximum pump efficiency with the final pump choice taking into account the most cost effective operations situation
- All pumps shall be operated from a three phase power supply system
- In calculating the head loss the effects of all bends and fittings beyond the pump discharge bend shall be allowed for, together with rising main friction losses based on a roughness "ks" value of 1.5mm. (Colebrook White formula)
- The system static head shall be based on the difference in level between the flange of the pump discharge bend and the highest point of the rising main system
- If the discharge is to an existing rising main, the head shall be calculated to include the operating head in the existing rising main
- The pump and rising main selection shall ensure that the minimum velocity in the rising main is 0.75m/s and the maximum velocity is 3m/s under normal operating conditions
- The gravity outlet system to which the station discharges shall be designed to accommodate the full discharge of pumps operating under emergency conditions in combination with the peak design flow from the adjoining gravity system
- A system head curve is to be calculated and plotted on the pump curve for the proposed pumps to ensure pump selection is adequate and shall be submitted for approval
- The system head curve shall also be calculated for a roughness 'ks' value of 0.1mm, and compared with the selected pump curve to ensure that the pump is not operating beyond the stable zone of its own pump curve

### 5.1.18.4 Wet Well and Storage Well

All wet and storage wells shall be constructed in accordance with the following requirements:

- The tops of the structures shall be designed to accommodate all anticipated loadings with particular regard to the close proximity of maintenance and service vehicles
- The wet well sump volume (between duty pump start and stop level) shall be designed to limit pump starts to a maximum of 10 per hour, as well as to accommodate a minimum 300mm depth, whichever is the greater
- The design and construction of the wet and storage well foundations shall ensure minimum settlement of the completed structure and provide adequate safety against flotation and liquefaction
- In determining the appropriate well diameter the minimum clearance between individual

---

pumps and side clearances shall comply with the manufacturers recommendations, together with accommodating full benching of the base

- Where a separate well is considered necessary to accommodate the emergency storage volume it shall be benched to direct all flow to the outlet point. The benching shall be a minimum gradient of 1 in 3 to allow self draining. A central channel within the storage well with a minimum gradient of 1% is acceptable
- The invert level of the storage well shall be a minimum of 100mm above the standby pump start level.
- The storage well shall not drain directly to the wet well unless specifically approved by the Engineer
- The wet well shall have a single inlet pipe
- The duty and standby pump start levels shall be located at a level lower than the invert level of the inlet pipe
  
- The pump and storage wells shall be underground and shall be fitted with lockable aluminium lids
- The finished lid level shall be 150mm above the surrounding ground
- The pump well shall be vented with either a galvanised or stainless steel stack with bird entry prevention. The height of the vent shall be no lower than the top of the electrical cabinet
- Details of the hanger bar and chain details for the pumps are to be submitted for approval
- All bolt fittings for attachments are to be stainless steel and where required are to be drilled and fixed into the concrete walls, using an approved epoxy grout in accordance with the manufacturers instructions
- All pipes and pipe fittings from the pump discharge bend to the Gibault joint outside the valve chamber shall be ductile iron and shall be coated with Rilsan Nylon 11 or an equivalent approved coating. All pipes and fittings shall be not less than 100mm for standard pumps.

#### 5.1.18.5 Valve Chamber

The valve chamber shall be constructed in accordance with the following requirements:

- It shall be below ground level and constructed with either reinforced concrete or concrete block walls, attached to the pump well by means of starter bars, fixed by drilling and setting with an approved epoxy grout into the pump well
- Where the valve chamber is below winter water table levels, the concrete block walls shall be coated with an approved bituminous waterproofing system
- The chamber floor shall be reinforced concrete
- The chamber shall be fitted with lockable aluminium lids
- All valves shall be Rilsan Nylon 11 coated and non-return valves shall be swing-check valves with full bore openings nylon coated
- A 50mm diameter drainpipe shall be fitted between the valve chamber and the pump well with a push/pull knife valve to allow draining of the valve chamber into the pump well from lid level
- All pipe fittings through the valve chamber and pump well walls shall be ductile iron with

slip joints

- Provision shall be made to bypass the pump in case of breakdown

#### 5.1.18.6 Emergency Provisions

Pump stations shall have emergency storage in case of mechanical or electrical failure or blockage of the pumps or rising main. The storage must be located at such a level as to prevent overflow from any manholes, gully traps, pump station lids or any other outlet from the system. Emergency storage capacity equal to eight hours at the design average hourly flow is to be provided.

All stations shall be constructed with a standard plug for the connection of the Council's mobile generator. All pump stations shall have an approved and controlled overflow system which discharges in such a manner to ensure maximum storage is used prior to discharge. The overflow discharge must avoid ponding on private property and shall be directed to the nearest public stormwater system

#### 5.1.18.7 Rising Mains

The following materials are acceptable for rising mains;

- PVC-U (To AS/NZS 1477)
- PVC-UM (To AS/NZS 1477)
- PE80B (To AS/NZS 4130)
- PE100 (To AS/NZS 4130)

The selected pressure class shall be based on analysis of the rising main for maximum pump head, transient pressures under power failure, temperature of fluid being conveyed, the number of operational cycles over a 100 year life span and a factor of safety against rupture of 1.25.

Notwithstanding the above, the minimum acceptable PVC/PN ratings are as follows:

- PVC U PN 9
- PVC M PN 12.5

The minimum nominal bore for standard pumps is 100mm.

Where possible, to minimise the need for air release and scour valves, the gradient of the rising main shall be designed to avoid over verticals and under verticals.

To accommodate all out of balance forces on the main, its installation shall be similar to that of a water main, incorporating suitable anchorage of the pipe at all changes of direction. The bearing area of all anchor blocks shall be specifically designed for the ground conditions and shall be subject to approval by the Engineer.

Elastomeric seal joints shall be used for all PVC pipework. Solvent cement joints are not acceptable.

Rising mains shall be marked with tracer tape or wire in accordance with the details set out in Clause 5.1.17.

---

Rising mains in private property shall be located clear of building sites and the alignment shall be protected by an "Easement in Gross" in favour of the Council.

#### **5.1.18.8 Electrical Controls**

The electrical cabinet and controls shall be in accordance with the following requirements:

- The control cabinet shall be above ground level and shall be constructed in accordance with Standard Drawings SS 15 and SS 16.
- The telemetry equipment shall be Qtech Datran as used by the Whakatane District Council, and is to be programmed to communicate to Council's base. The functions and requirements of the module shall be as required by the Engineer
- The radio telephone shall be Tait
- A 12v 60 amp hour Jell-cell battery shall be fitted that will operate the telemetry in the event of a power failure
- The antenna pole shall be attached to the side of the cabinet
  
- The pump control is to be provided by means of an ultrasonic level transducer installed in the pump well and connected to the telemetry
- Each pump shall have an Auto/Manual/Off control switch and ammeter
- Hour run meters shall be provide for both pump sets
- A high level alarm shall be installed at an appropriate level in the pump well
- An internal fluorescent cabinet light and a general purpose 3 phase 32 amp residual current protected socket outlet shall be provided
- The thermal protection devices installed in the pump windings and wired in the pump flexible cable shall be connected into the pump protection circuit
- The pumps shall be connected by a plug and socket arrangement installed in the pump well or alternatively, the plug and socket may be fitted within the control cabinet
- The electrical cables from the pump well shall pass through the side wall of the well via an isolating gland. The duct for the gland and cables shall be 150mm diameter
- A 12 volt DC flashing light shall be installed near the top of the telemetry aerial pole and be connected for fault warning
- The cabinet shall include all power supply company equipment. All negotiation and supply co-ordination shall be carried out by the electrical contractor
- Cabinet design shall be in accordance with Standard Drawing SS 16.
- Cabinet layout and labelling shall be submitted to the Engineer for approval before construction is commenced.

Detailed data sheets which specify the particular requirements for the control cabinet, the switchboard and the telemetry controls, hardware and programming are available from the Council. These show the required acceptable hardware and the details of the electrical installation, as well as the pump requirements and operational controls. These requirements are to be adhered to so as to ensure compatibility with the equipment and operation of the present control and monitoring systems.



#### **5.1.18.9 Pump Duty**

Pumps shall be controlled so that while one pump is acting as duty pump, the other is on automatic standby. The switchboard configuration shall allow the duty sequence to be interchanged remotely via the District Council Telemetry System, and shall be set to automatically rotate the duty pump every two weeks.

#### **5.1.18.10 Power Supply**

The power supply to the station shall be underground.

#### **5.1.18.11 Water Supply**

A 25 mm water supply shall be provided adjacent to the pump station. The supply shall be fitted with a 25mm backflow preventer in accordance with clause 6.2.3.2 of Section 6 of this standard and Standard Drawing SS 18, and to the approval of the Engineer

The backflow preventer and associated components shall be installed in a lockable aluminium box adjacent to the electrical cabinet. Access to the backflow preventer and Camlock connection to meet maintenance, testing and operational requirements shall be provided.

The backflow preventor shall be fitted and certified by an approved installer.

The supply shall be fitted with an approved meter, which shall be installed by the Council at the developers cost.

### **5.1.19 TREATMENT PLANTS**

#### **5.1.19.1 General**

In special cases where a treatment plant is required, the subdivider must construct a plant to a design that is satisfactory to the Engineer and Environment BOP. The design must have the prior approval of these authorities and be subject to the issue of a building consent. Resource consents may be required and where necessary, must be obtained by the subdivider prior to the commencement of any engineering works within the subdivision.

#### **5.1.19.2 Power Supply**

The power supply to the plant must be underground.

#### **5.1.19.3 Water Supply**

The treatment plant is to be provided with a water supply in the immediate vicinity in accordance with Clause 5.1.18.7 above.

#### **5.1.19.4 Access**

Sealed vehicle access and manoeuvring areas must be provided to the plant.

**5.1.19.5 Fencing**

The area around the plant must be fenced and provided with a suitable locked gate, all to the Engineer's satisfaction.

**5.1.19.6 Site**

The site of the plant shall be on a separate lot with access to a formed road. If the plant is only required on a temporary basis while other sections of the reticulation are being constructed, it shall be removed after it is no longer required, and the area may revert to any suitable use the subdivider may stipulate.

In certain cases, Council may require that the site and plant be vested in Council. In such a case, specific conditions will be set by Council at the time of the subdivision consent approval.

## CHAPTER 5

### WASTEWATER

#### STANDARD DRAWINGS

SS 01	.....	Standard Sewer Connections
SS 02	.....	Internal Drop Connection 100mm Diameter Pipes
SS 03	.....	Internal Drop Connection 150 & 225mm Diameter Pipes
SS 04	.....	Standard Cleaning Eye
SS 05	.....	Standard Sewer Manhole
SS 06	.....	Heavy Duty Manhole Cover and Frame
SS 07	.....	Manhole Stepped Rungs
SS 08	.....	Private Drain to Public Sewer
SS 10	.....	Private Drain to an Existing Lateral Connection
SS 11	.....	Sewer Pump Station Internal Layout
SS 13	.....	Sewer Pump Station Cover Slab and Lid Details
SS 14	.....	Sewer Pump Station Electrical Cabinet
SS 15	.....	Sewer Pump Station Control Cabinet Layout
SS 16	.....	Sewer Pump Station Backflow Prevention Detail



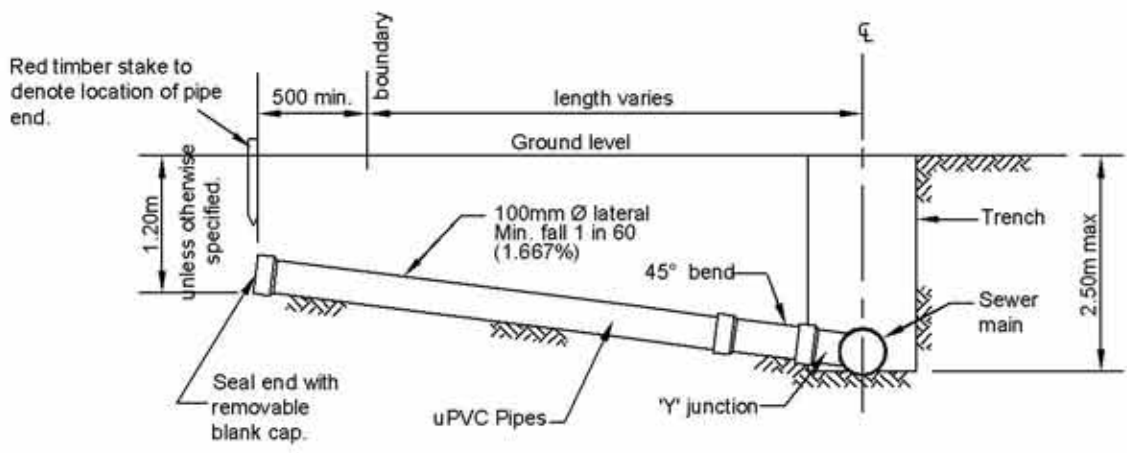

**STANDARD CONNECTION FOR SEWERS WITH A DEPTH TO INVERT LESS THAN 2.50m - SECTION**

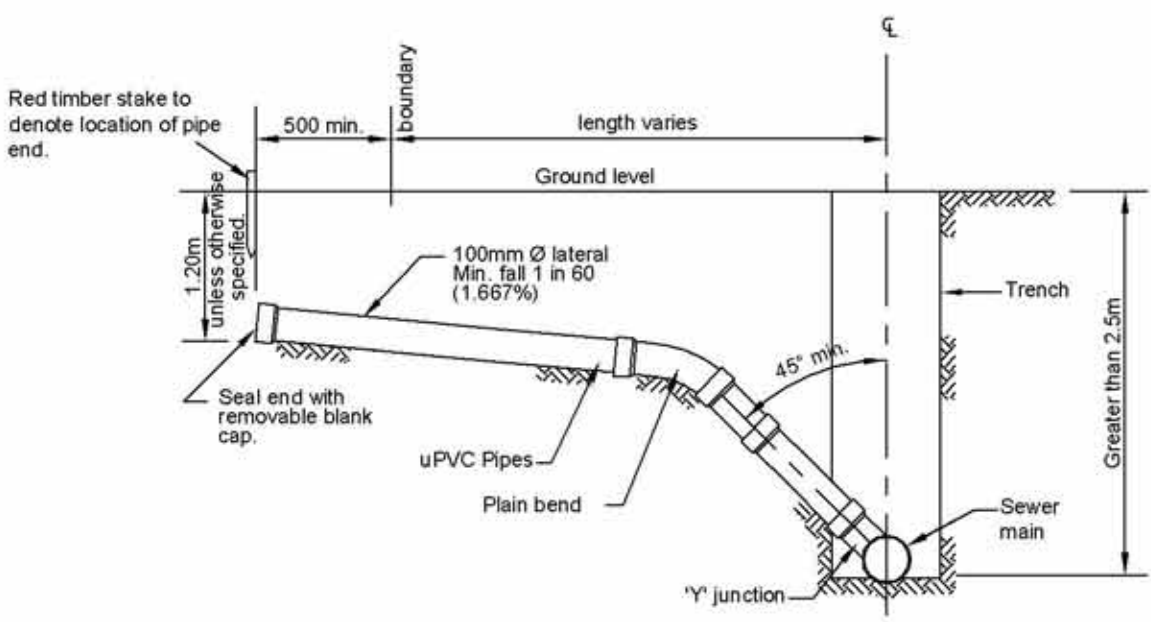

**RAMP RISER CONNECTION FOR SEWERS WITH A DEPTH TO INVERT GREATER THAN 2.50M - SECTION**

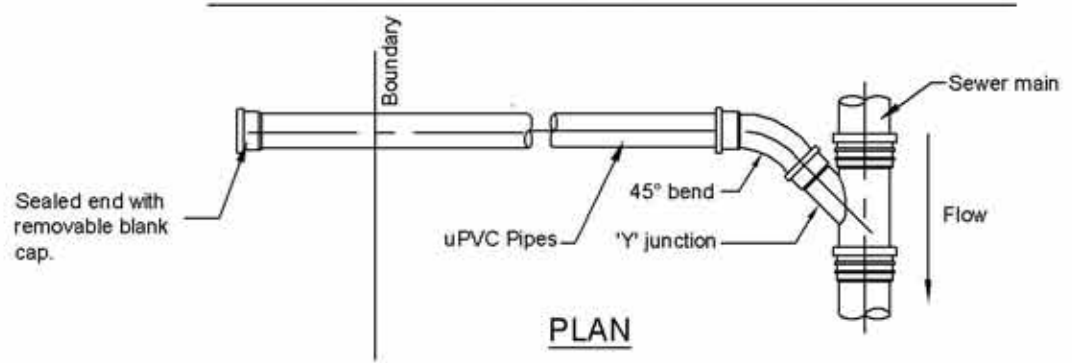

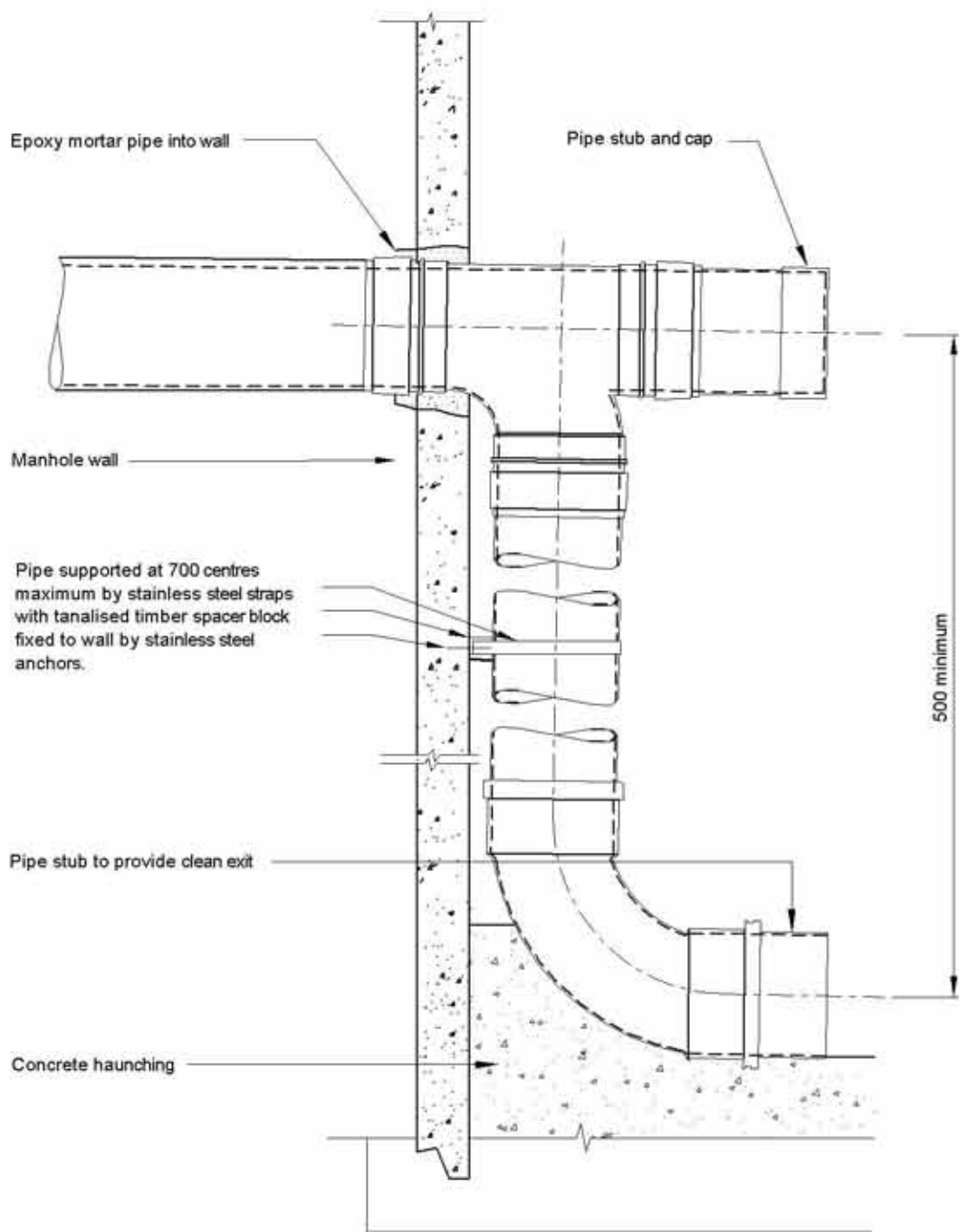

WHAKATANE  
DISTRICT  
COUNCIL



PREPARED BY ORIS

**STANDARD DRAWING**

NOT TO SCALE

**INTERNAL DROP CONNECTION  
100mm DIAMETER PIPES**

**SS 02**

ISSUE 7.0  
SEPTEMBER 2007

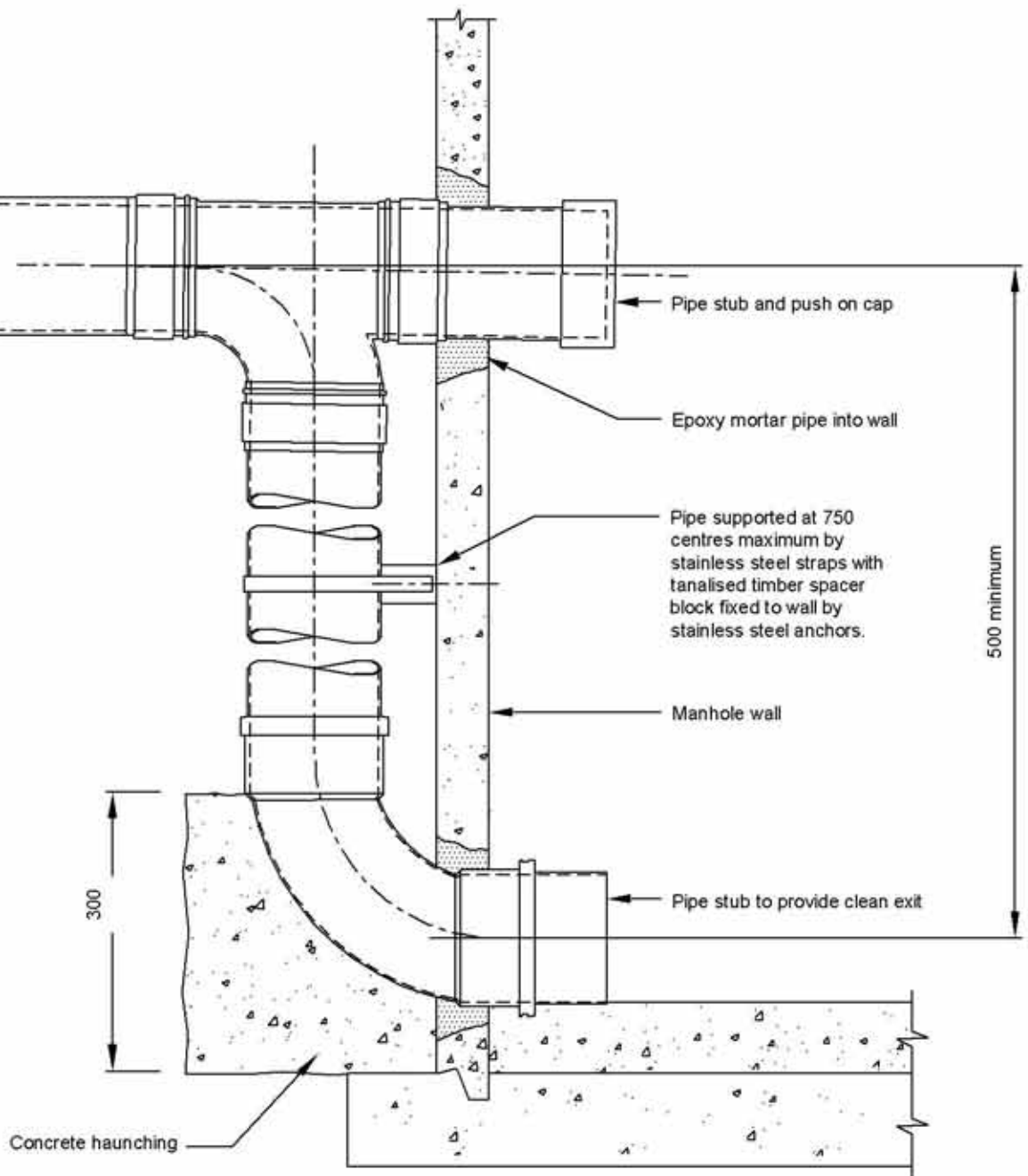

WHAKATANE  
DISTRICT  
COUNCIL



PREPARED BY  OPUS

## STANDARD DRAWING

NOT TO SCALE

## EXTERNAL DROP CONNECTION 150mm & 225mm DIAMETER PIPES

# SS 03

ISSUE 7.0  
SEPTEMBER 2007

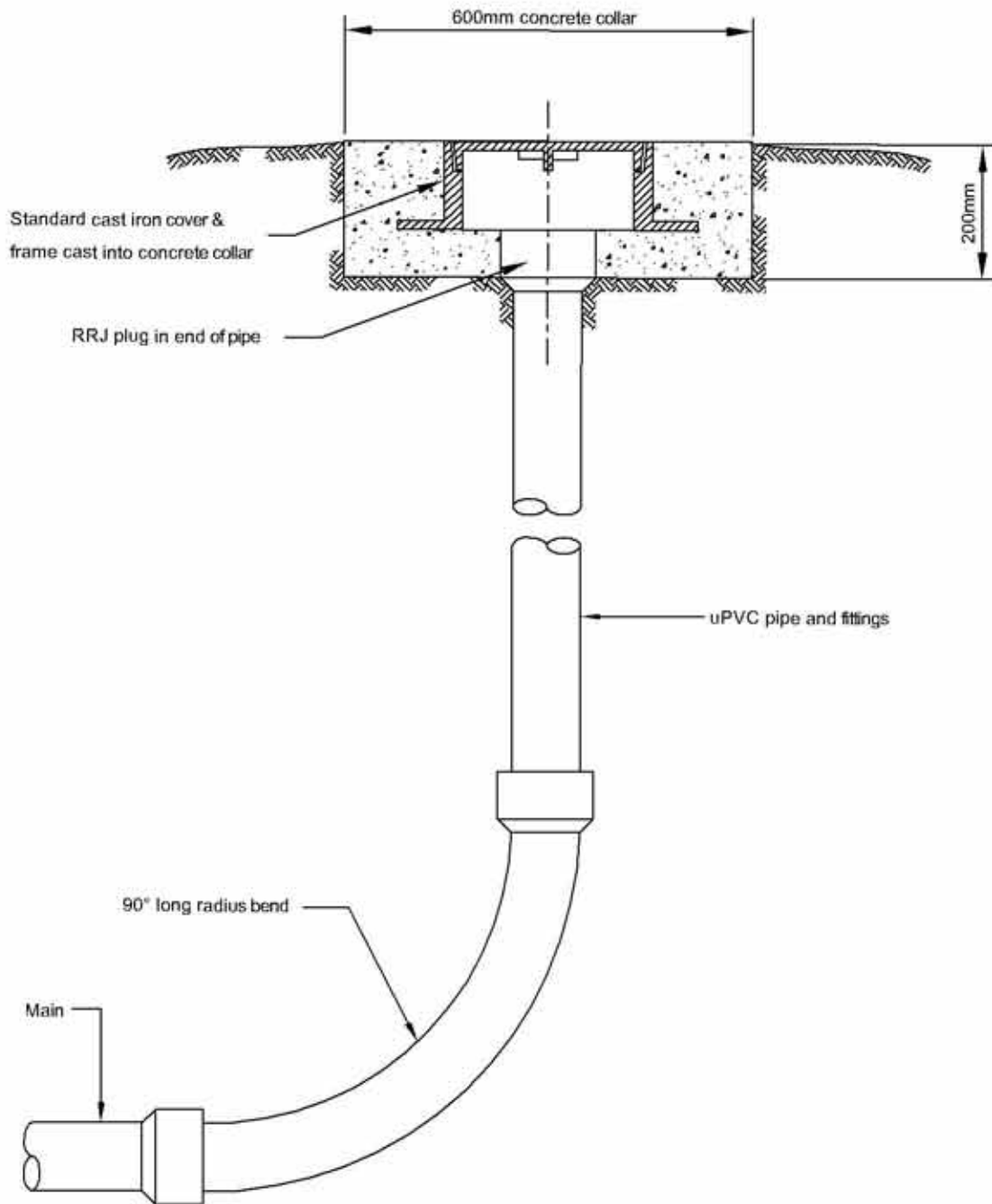

WHAKATANE  
DISTRICT  
COUNCIL



PREPARED BY



STANDARD DRAWING

NOT TO SCALE

STANDARD CLEANING EYE

SS 04

ISSUE 7.0  
SEPTEMBER 2007



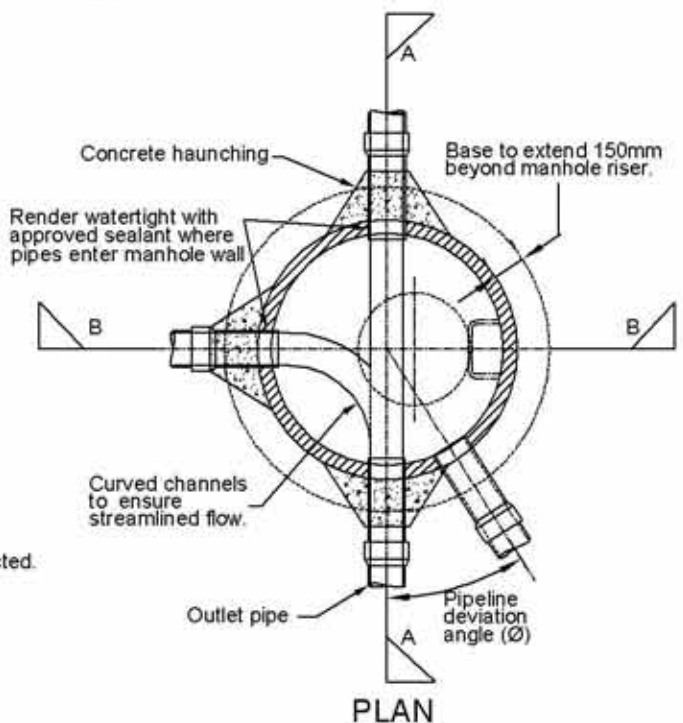
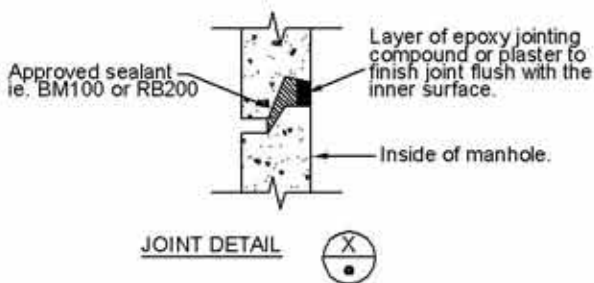
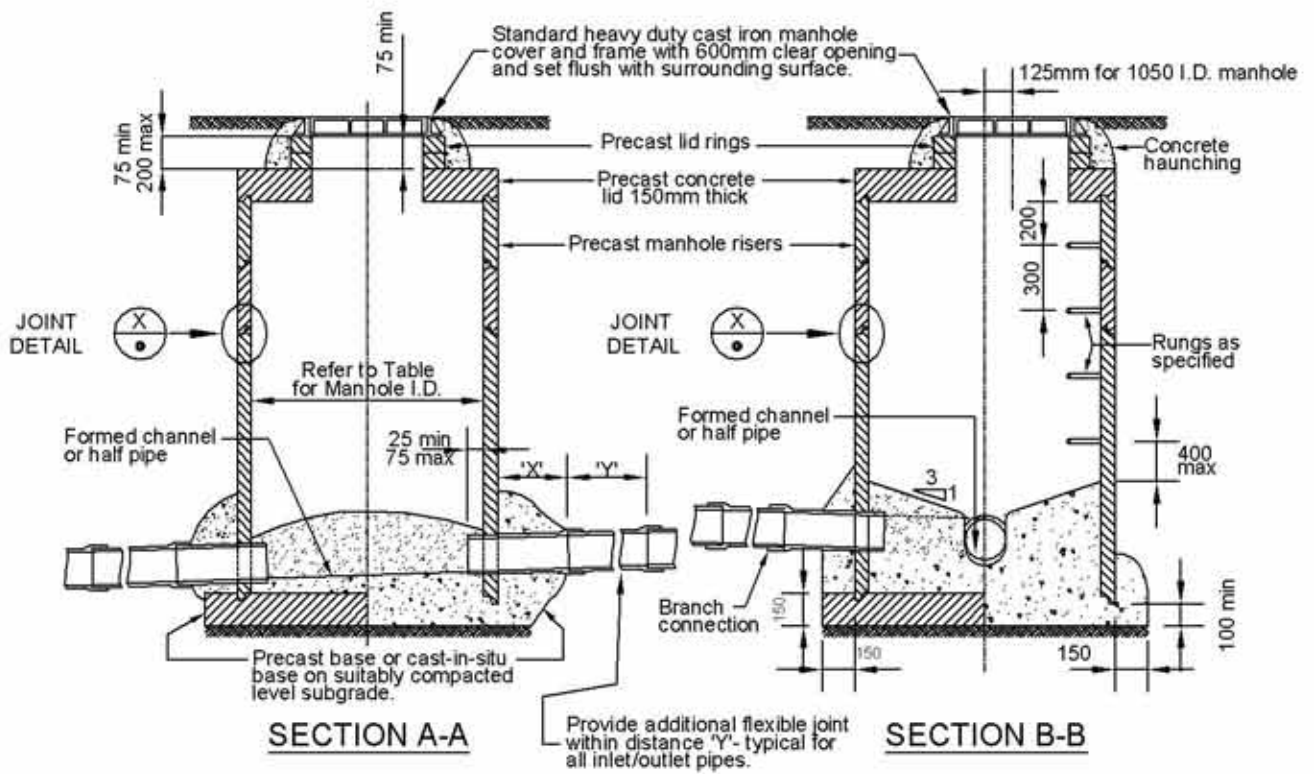

OUTLET PIPE Dia (mm)	MINIMUM MANHOLE INTERNAL DIA (mm) *				X' (mm)	Y' (mm)
	0°-15°	16°-45°	46°-75°	76°-90°		
Up to 300	1050	1050	1050	1050	300	500
375 to 600	1050	1050	1050	1050	500	700
675 to 750	1050	1200	1500	1500	600	750
825 to 900	1500	1500	1800	1800	600	900

\* To be used as a guide only. Larger diameters may be required where more than one inlet pipe is to be constructed.

**Notes**

1. All in-situ concrete other than site concrete shall have a minimum compressive strength of 20 MPa at 28 days.
2. All precast manhole units (shown shaded) are standard manufactured concrete units from a certified precast supplier



**STANDARD DRAWING**

NOT TO SCALE

**STANDARD SEWER MANHOLE**

**SS 05**  
ISSUE 7.0  
SEPTEMBER 2007

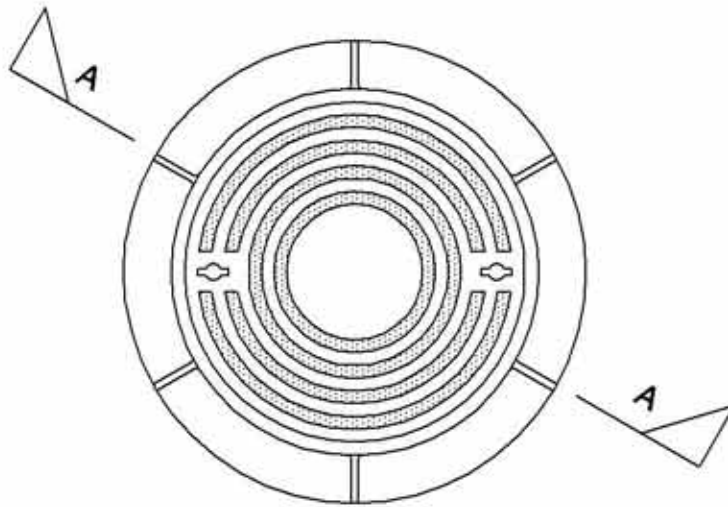

**PLAN**

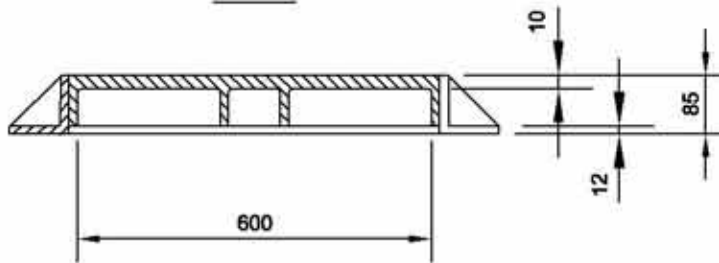

**SECTION A-A**

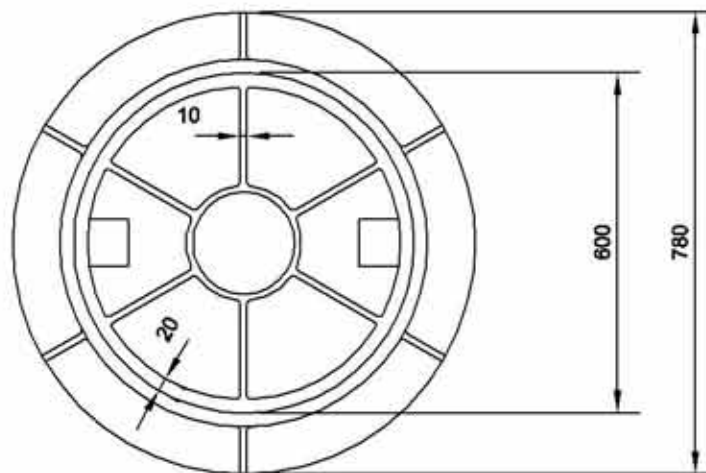

**BOTTOM VIEW**

Approx weights  
 Cover 48 kg  
 Frame 40 kg



**STANDARD DRAWING**

NOT TO SCALE

**HEAVY DUTY MANHOLE  
 COVER AND FRAME**

**SS 06**  
 ISSUE 7.0  
 SEPTEMBER 2007

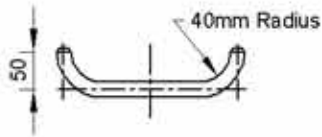

ELEVATION

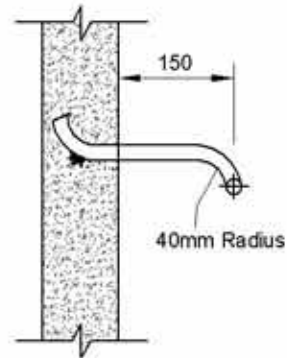

SECTION (Cast in Situ)

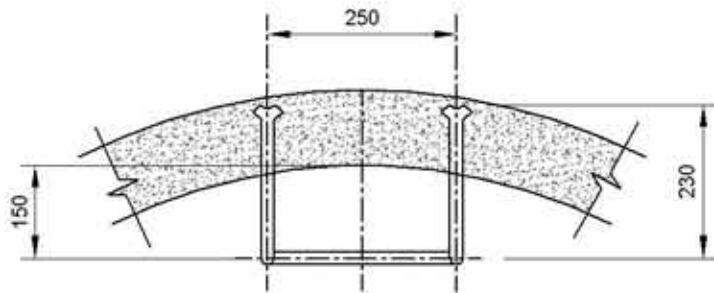

PLAN (Cast In Situ)

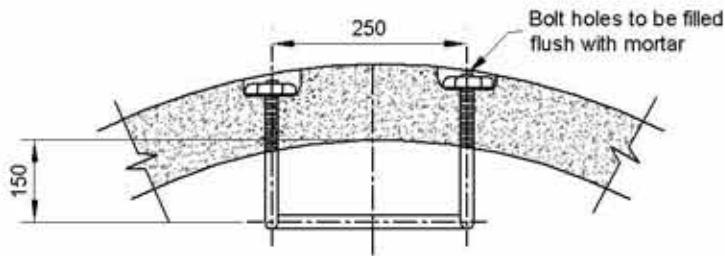

PLAN (Precast)

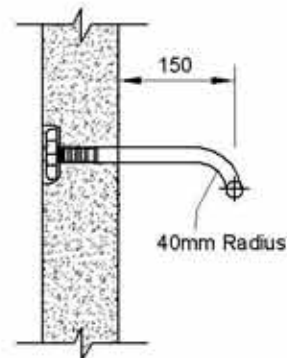

SECTION (Precast)

**Note:**

- Stepped rungs shall be fabricated from 20mm diameter mild steel rods, hot dipped galvanised after fabrication.
- The zinc coating is to be not less than 400g/sq.m.

DETAILS OF STEPPED RUNGS

WHAKATANE  
DISTRICT  
COUNCIL



PREPARED BY OPHS

STANDARD DRAWING

NOT TO SCALE

MANHOLE STEPPED RUNGS

SS 07

ISSUE 7.0  
SEPTEMBER 2007

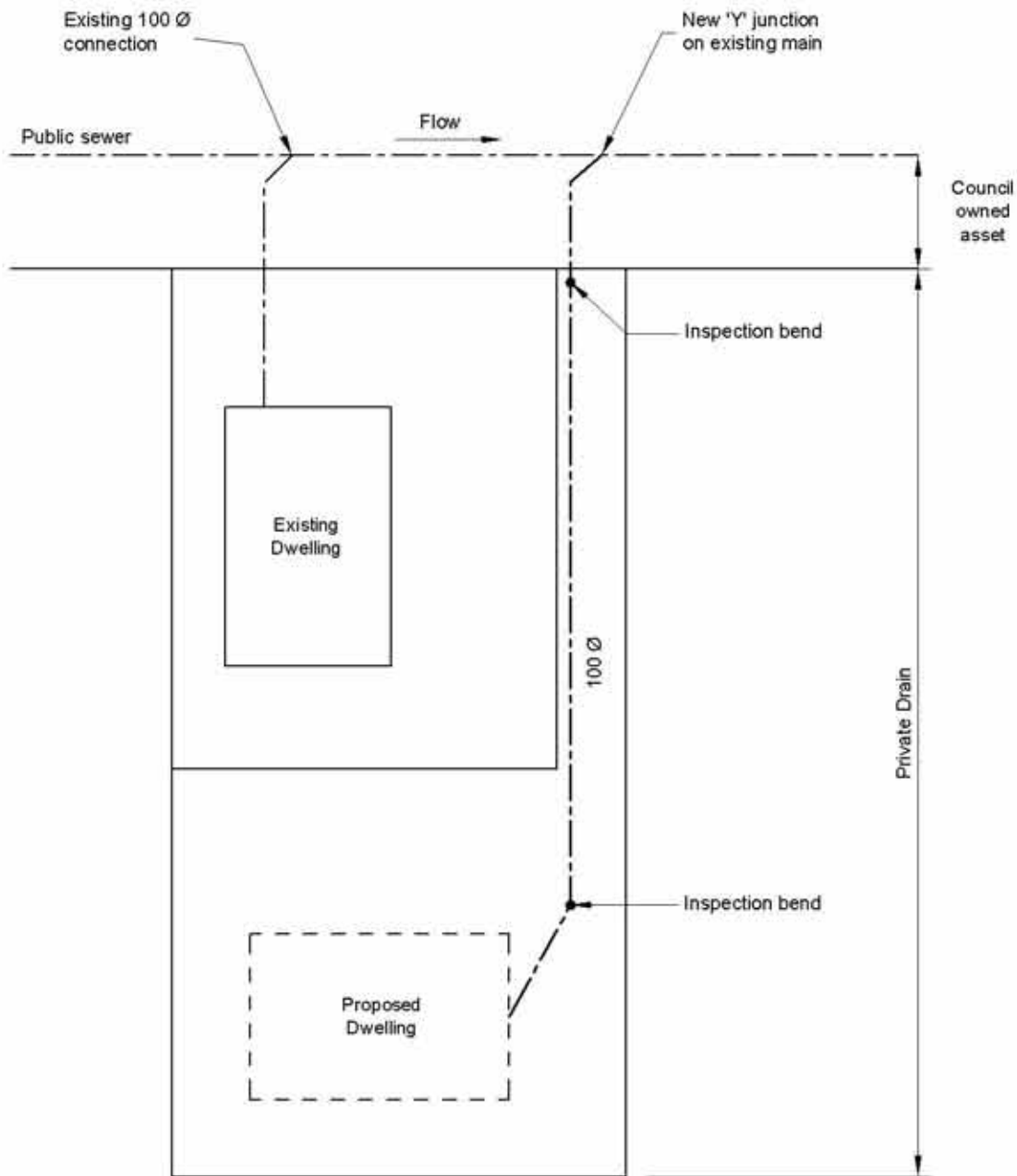

WHAKATANE  
DISTRICT  
COUNCIL



PREPARED BY  OPHS

## STANDARD DRAWING

NOT TO SCALE

## PRIVATE DRAIN to PUBLIC SEWER

# SS 08

ISSUE 7.0  
SEPTEMBER 2007



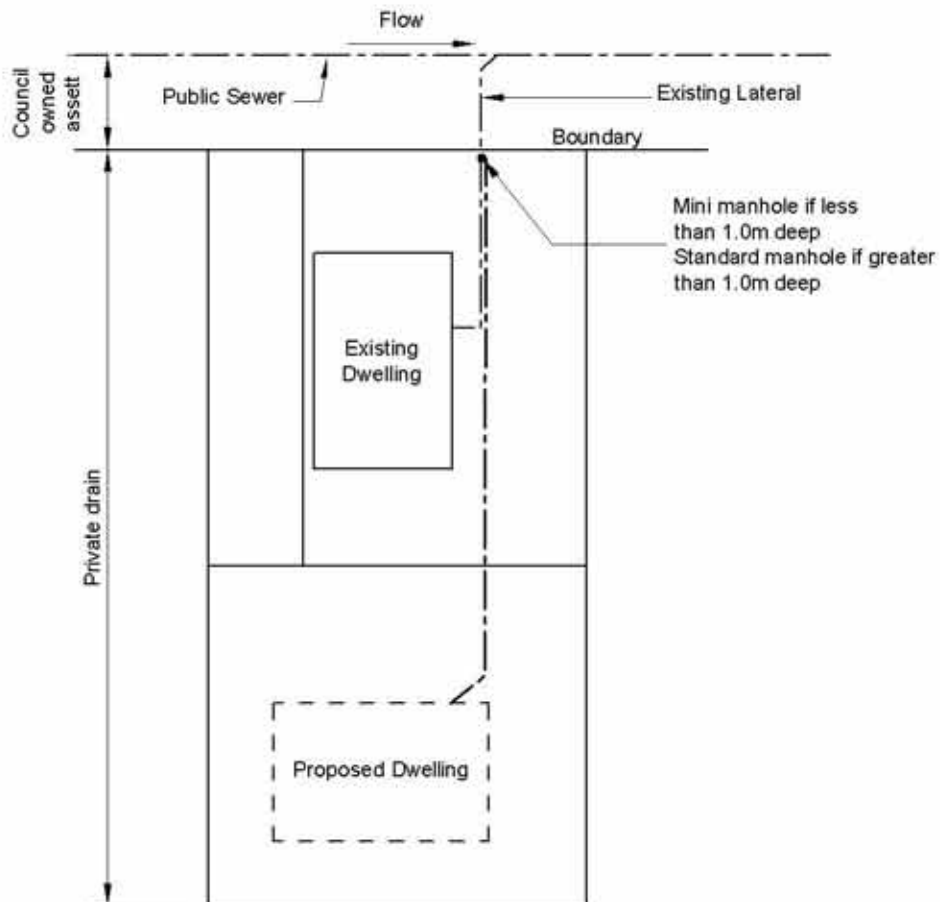

#### NOTES

1. A mini manhole may be installed if the lateral is less than 1m deep.
2. A standard manhole is required if the lateral is greater than 1m deep.
3. A sewer lateral inspection test will be required by the Council and will be carried out at the cost of the developer. If the test is passed then the connection will be approved. If the test is not passed then the developer will be required to upgrade the lateral to the required standard at their cost.

WHAKATANE  
DISTRICT  
COUNCIL



PREPARED BY  OPHS

STANDARD DRAWING

NOT TO SCALE

PRIVATE DRAIN to an  
EXISTING LATERAL CONNECTION

SS 10

ISSUE 7.0  
SEPTEMBER 2007

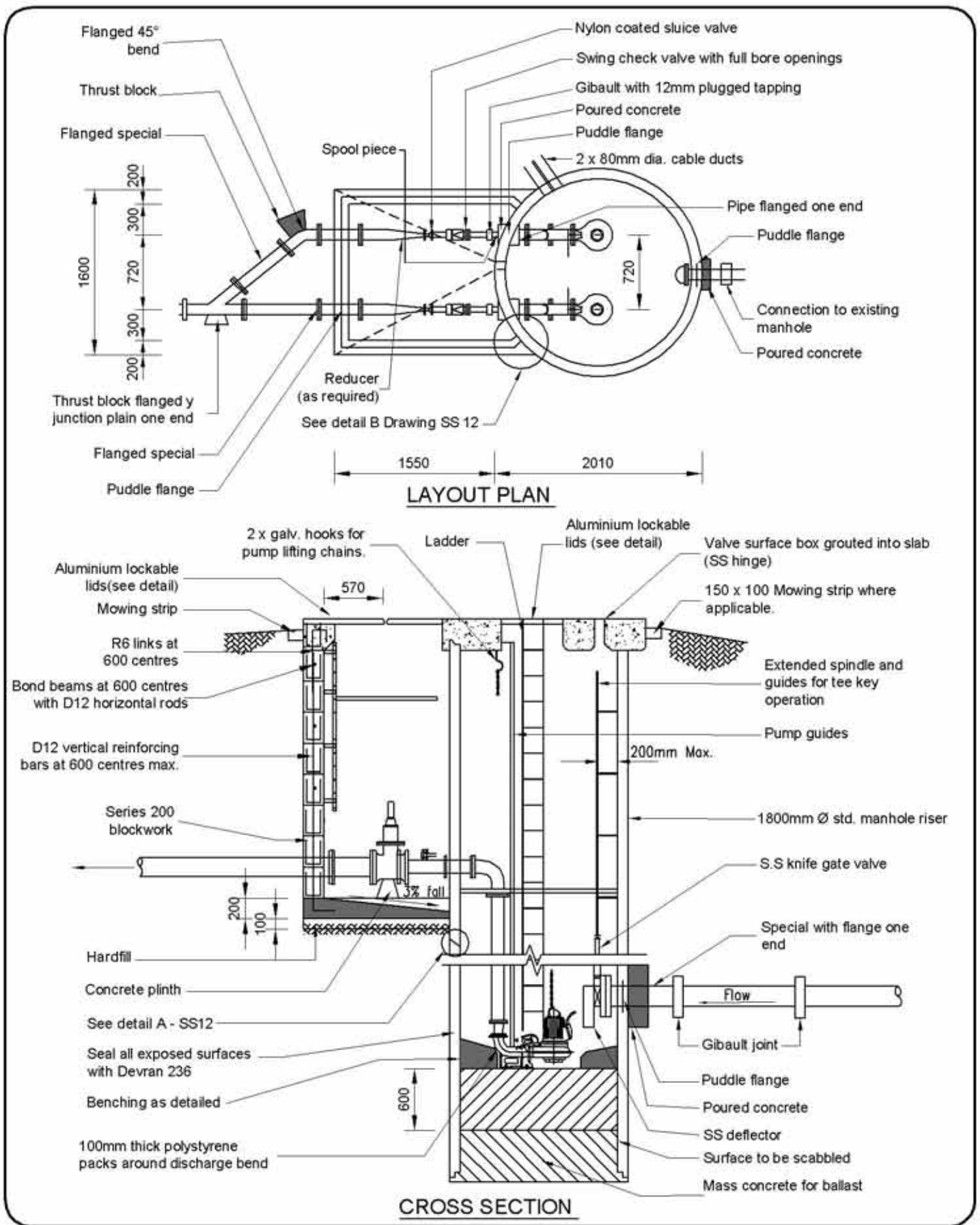

STANDARD DRAWING

NOT TO SCALE

SEWER PUMP STATION  
INTERNAL LAYOUT

SS11  
ISSUE 7.0  
SEPTEMBER 2007

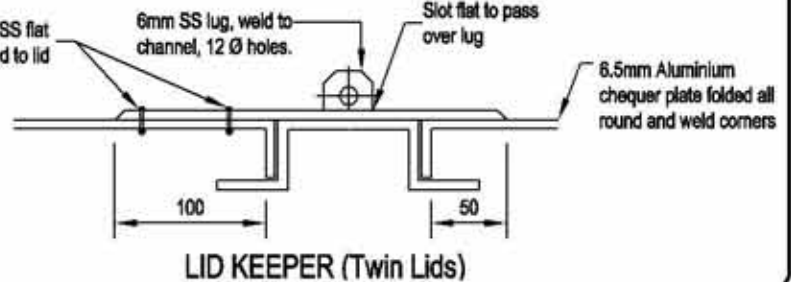
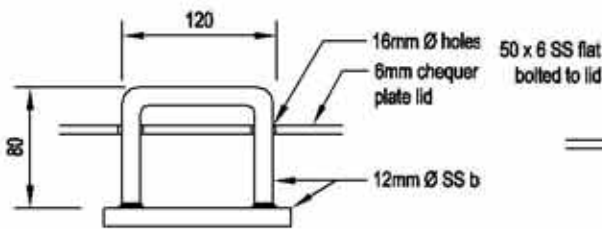
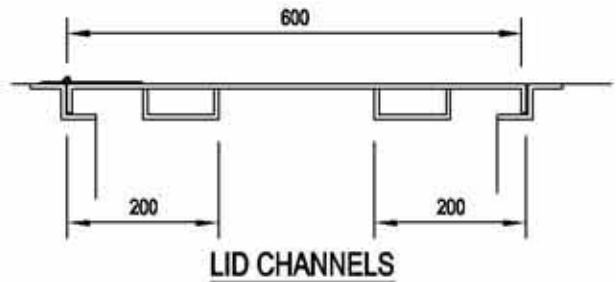
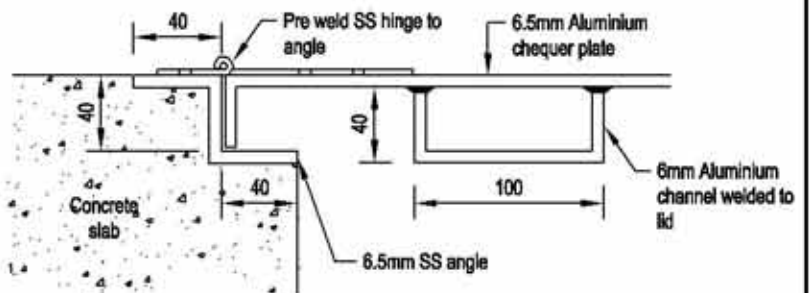
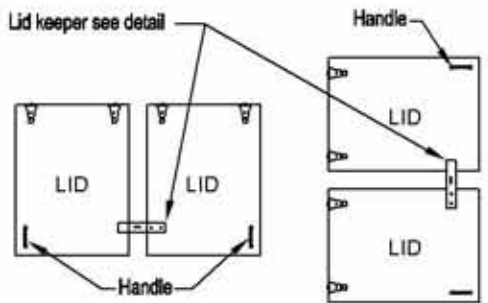
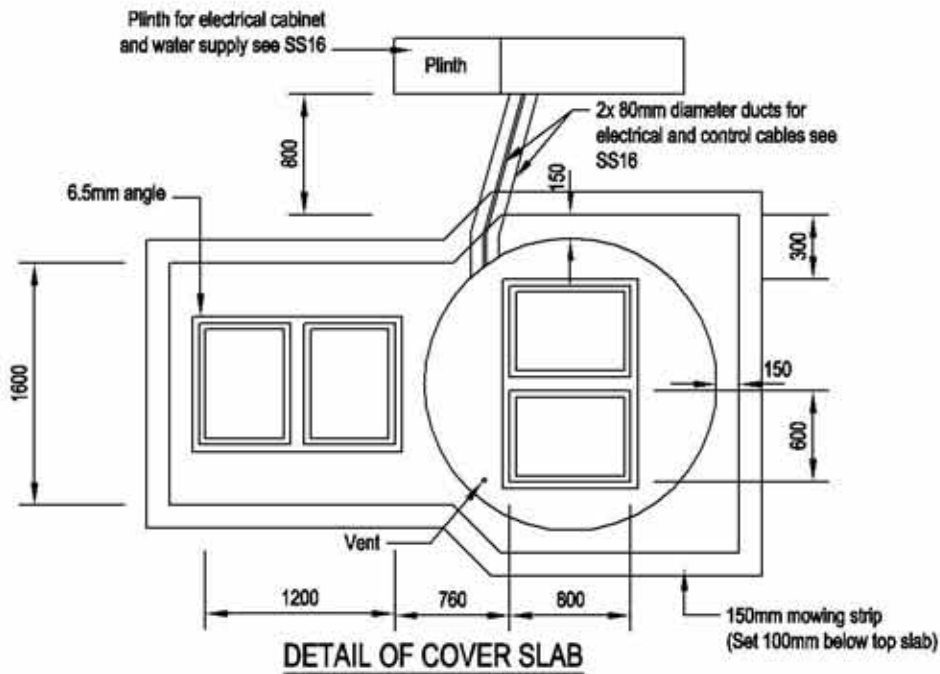

WHAKATANE  
DISTRICT  
COUNCIL



PREPARED BY OPHS

STANDARD DRAWING

NOT TO SCALE

SEWAGE PUMPSTATION  
COVER SLAB AND LID DETAIL

SS 13

ISSUE 7.0  
SEPTEMBER 2007

NOTES: Structure made from 3mm Aluminium plate unless shown otherwise. Finish to be powder coat, colour green.

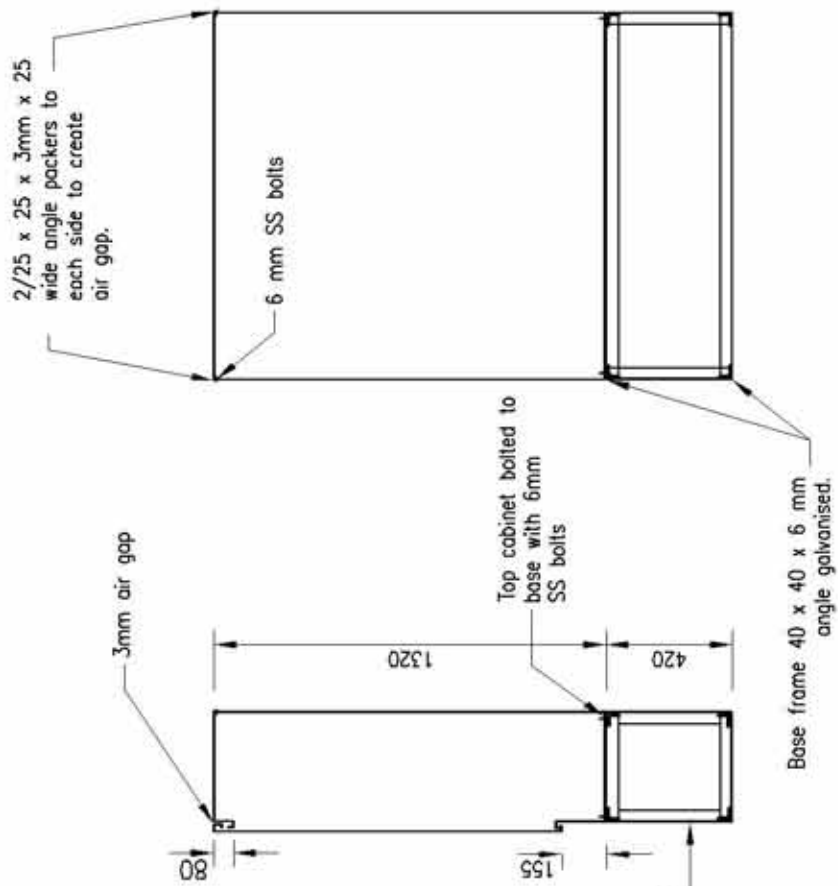
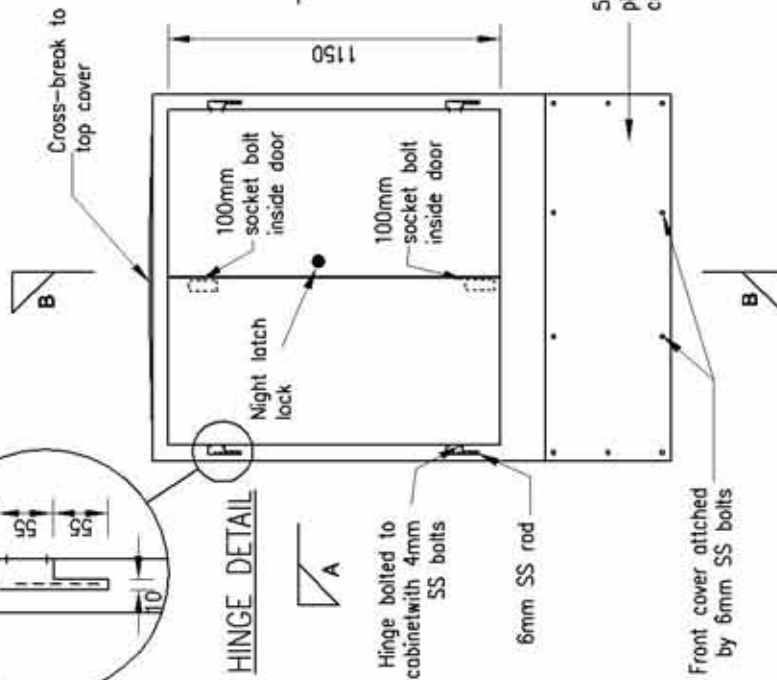
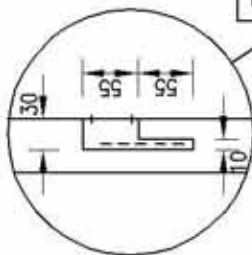
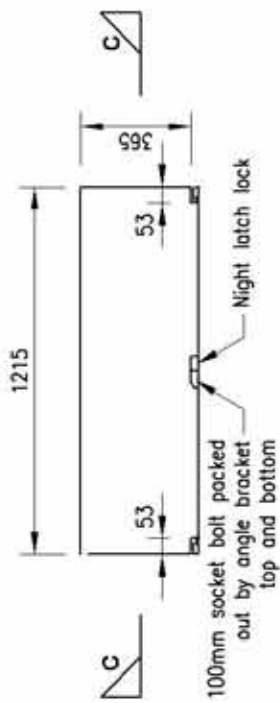

FRONT ELEVATION

SECTION B-B

SECTION C-C

WHAKATANE DISTRICT COUNCIL



PREPARED BY OPHS

STANDARD DRAWING

NOT TO SCALE

PUMP STATION ELECTRICAL CABINET

SS14

ISSUE 7.0  
SEPTEMBER 2007



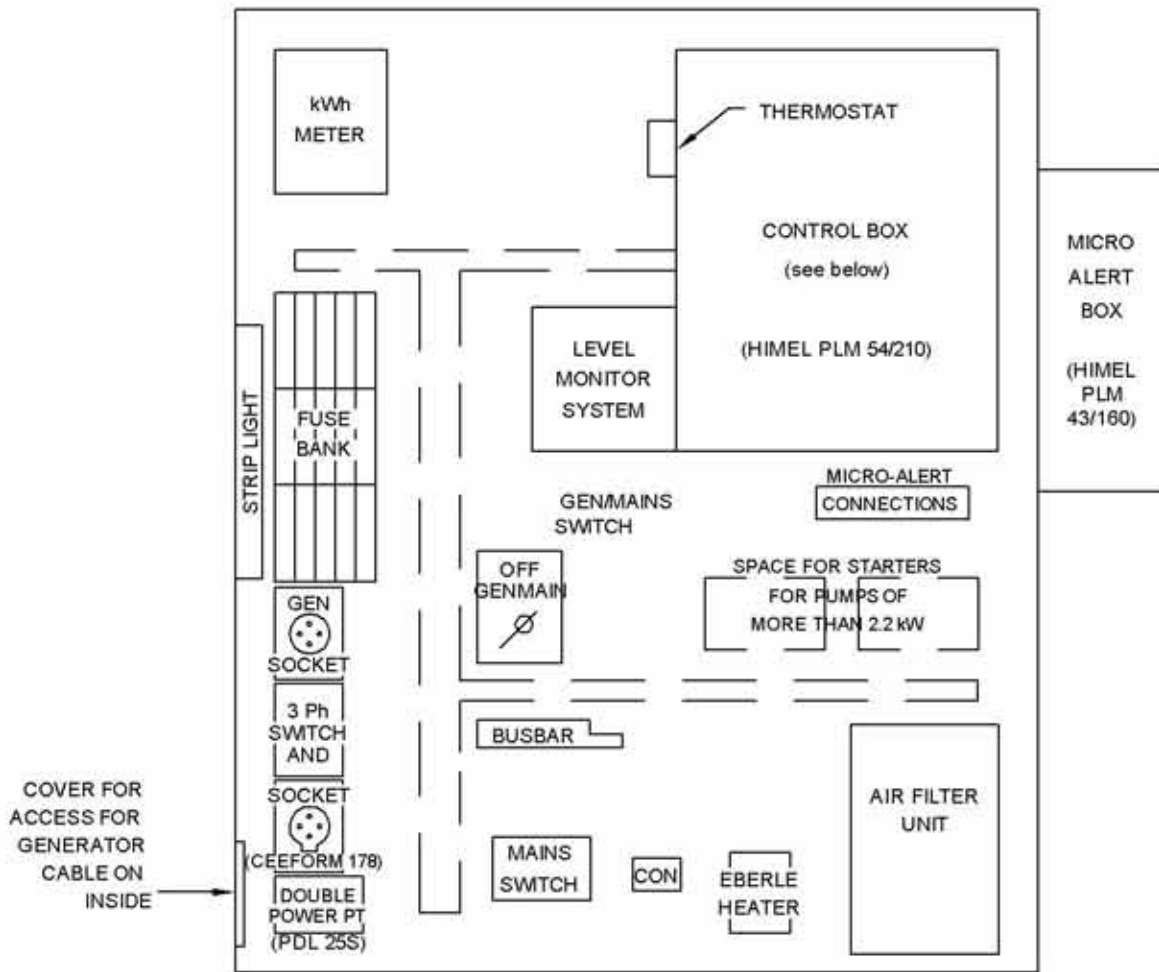

CONTROL CABINET LAYOUT

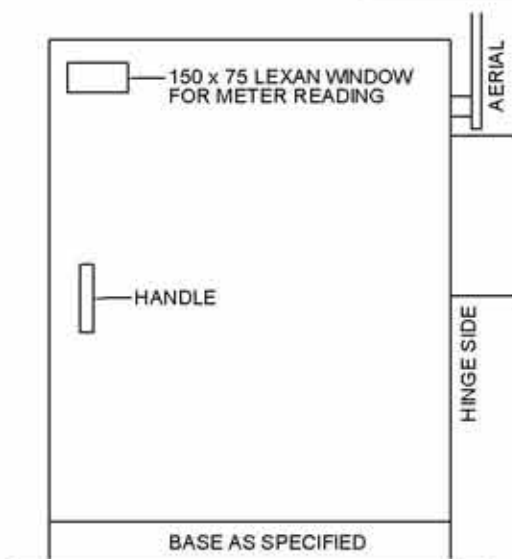

ELEVATION

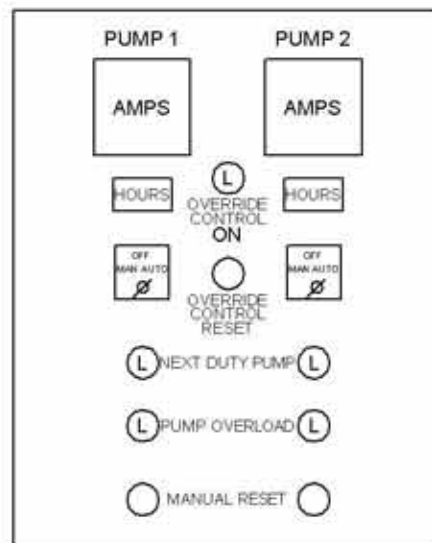

CONTROL BOX LAYOUT

WHAKATANE  
DISTRICT  
COUNCIL



PREPARED BY **OPUS**

**STANDARD DRAWING**

NOT TO SCALE

**SEWER PUMP STATION  
CONTROL CABINET LAYOUT**

**SS 15**

ISSUE 7.0  
SEPTEMBER 2007

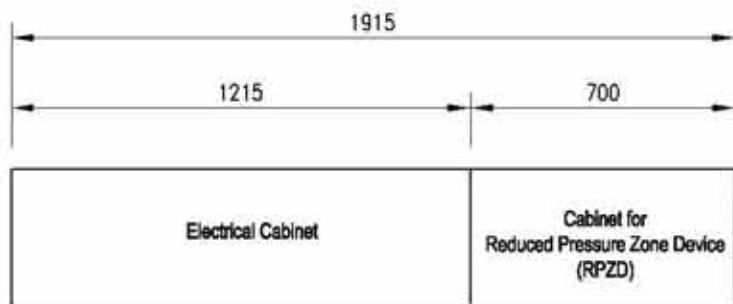

**PLAN**

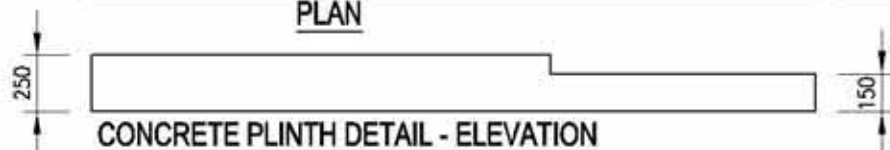

**CONCRETE PLINTH DETAIL - ELEVATION**

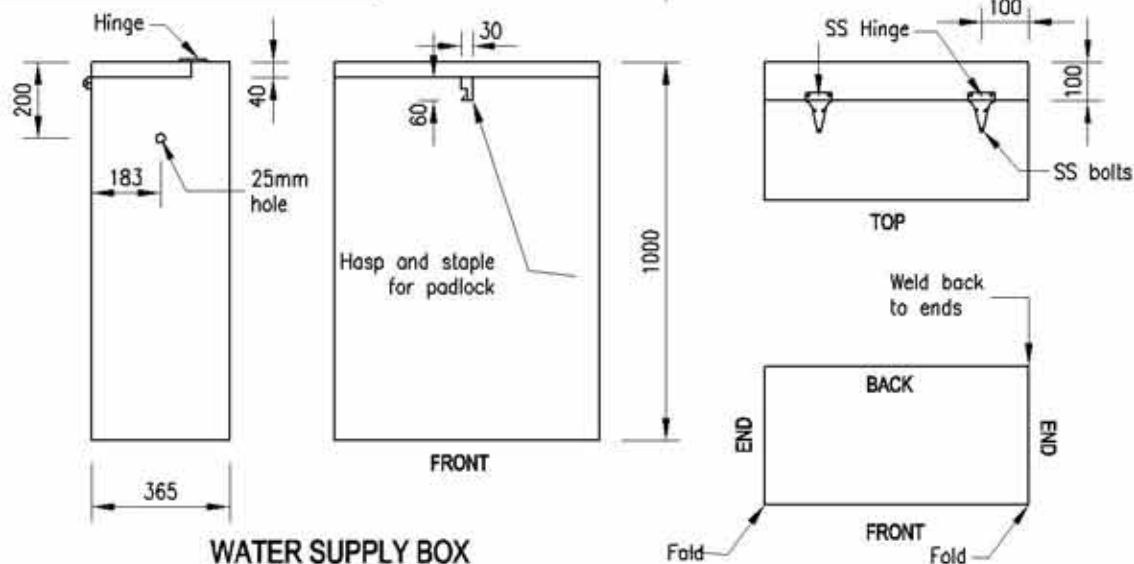

**WATER SUPPLY BOX**

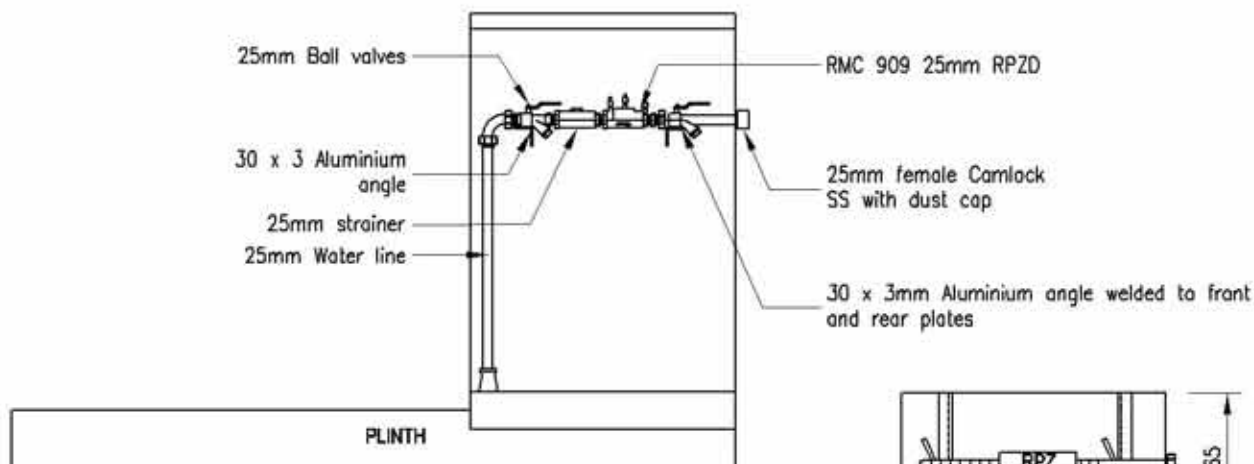

**INTERNAL LAYOUT**

NOTE: Structure made from 3mm aluminium finished in powder coat colour green.

SS strap over ball valve to angle

30 x 3 Aluminium angle welded to front and back



WHAKATANE DISTRICT COUNCIL



PREPARED BY OPUS

**STANDARD DRAWING**

NOT TO SCALE

**SEWER PUMP STATION  
BACKFLOW PREVENTION DETAIL**

**SS 16**

ISSUE 7.0  
SEPTEMBER 2007